

Grinding equipment

Product catalogue







Contents

The importance of grinding	4
The right tools	5
Grind Matic diamond grinding tools.....	6
A machine for every occasion.....	7
Secoroc grinding machines.....	8
Take care of your working environment	15
Accessories and consumables	17
Grinding hints.....	21
Know your drilling.....	22
Indexing templates.....	24

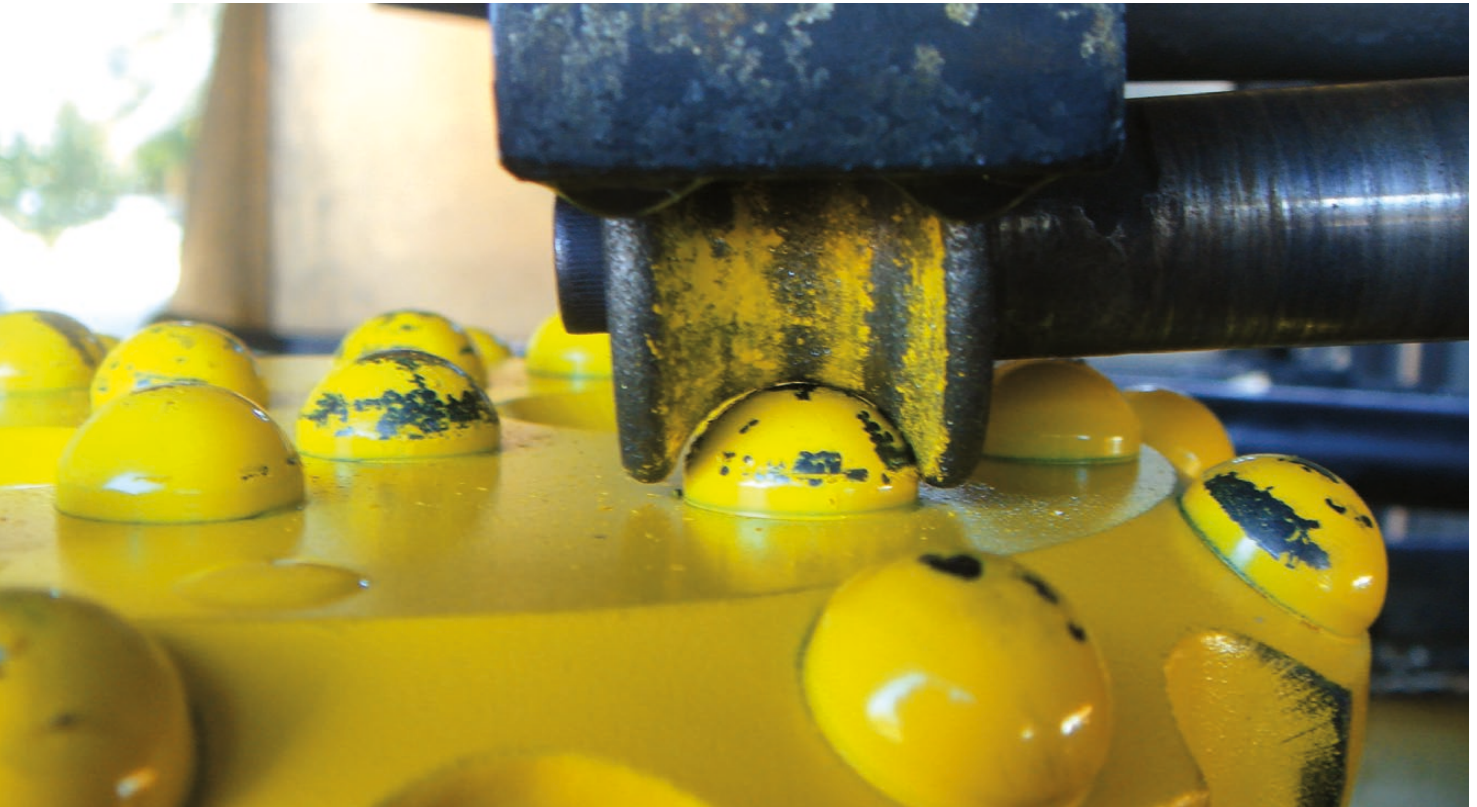

The importance of grinding

You've probably known for a long time that regular grinding is essential for productivity. But what you may not know is just how important it is. By wearing down your button bits by a third you'll slow down your penetration rate and at the same time increase your running costs! And why? Because the hole will take longer to drill and your labour and rig running costs will escalate. And at the end of the day you'll have drilled fewer holes.

History of grinding

The first man cracked a sample of seed of wild grass with his teeth or his nails, but found out that if he placed a bulk of the grains in a hollow of a natural stone and pounded it with another stone, it became easier for him to eat. The history of grinding wheels began therefore with natural composite stones, and were used for example as millstones.

Mankind continued to use grinding implements for domestic use, not only for preparation of food, but also to various tools in their everyday life. Later on in the human civilization, copper, iron sand and alluvial gold was used as materials for primitive metallurgical grinding processing methods. Today, we at Epiroc, can meet the needs of all our customers with large scale production.



The right tools to get you back on the cutting edge

Every regrinding operation requires its own special tool. The wrong one can easily damage your bits. With Epiroc grinding equipment – complemented by a global service organization – you needn't worry. Your bits will soon be as good as new.

Staying sharp makes a lot of business sense

If you spend your hard-earned money on drill bits that have to be constantly replaced, then you'll start wondering if you can't get better value elsewhere. The answer to this problem is a comprehensive range of grinding equipment. Maintaining penetration can therefore save you money.

Firstly, you need good grinding equipment for a start – and you won't find any better than Epiroc's. And secondly, you need to spend time and energy grinding your bits. But the rewards are significant. For a really small investment of your overall drilling costs, you can restore your worn bits to their former glory. And with these bits you cut the time and manpower needed to drill the hole. In fact, you will reduce overall drilling costs. How? By using the market's widest selection of efficient, ergonomically designed grinding machines for fixed installations and field operations – Epiroc grinding machines.

Get the sharpest advice

In a grinding machine, the grinding wheels are composed of abrasive compounds. Grinding wheels life span can vary from less than a day to many years, depending of the release of individual grains, dull grinding and that they increase drag pulls out of the bond. The process of manufacturing the grinding wheels is therefore a controlled and precise process and is necessary for good performance.

There are many different types of bits, some with inserts and others with buttons – and they come in many different sizes. To further complicate matters, no two rocks are the same. Consequently, bit wear differs. There's only one good piece of advice we can give you – don't make a decision before talking to us. And remember, thanks to Epiroc's extensive service network, a good grind is only a phone call away.

Epiroc can offer grinding machines for fixed installations and field operations; for tapered, tophammer and DTH button bits; as well as integrals with chisel inserts.



Diamond grinding tools deliver perfect results

With Epiroc's diamond grinding wheels that retain their profiles throughout their entire working life, you can be sure that they deliver perfect results. Every time.

Diamonds are a driller's best friend

If you need to grind steel and cemented carbide in one single operation, you won't find better tools than our diamond grinding wheels for spherical, ballistic and the patented Trubbnos cemented carbide buttons. Thanks to the diamond coated steel body, these grinding wheels retain their profile throughout their working life. So when used in our grinding machines these wheels always deliver perfect results.

There's no other way to grind buttons properly.

Grinding cups for button bits, COPROD and down-the-hole bits

Grinding cups are used, for smaller grinding volumes, to grind both tophammer button bits and down-the-hole bits, with our superior air powered handheld grinding machine. Featuring a special abrasive mixture, Grind Matic grinding cups are able to grind cemented carbide and steel in one single operation. You can use either air or water as a coolant.

It's safe to say that handheld grinding has never been cheaper, easier or quicker.



Grind Matic grinding wheels for button bits.



Grind Matic grinding cups.

A machine for every occasion

Grinding machine	Threaded and tapered bits	DTH and COPROD bits	Reaming bits
Grind Matic BQ3	●		●
Grind Matic BQ3-DTH	○	●	○
Grind Matic Manual B	●		●
Grind Matic Manual B-DTH*	○	●	○
Grind Matic RH3	●	●	○

● Recommended ○ Can be used

* Can be used for ODEX pilot bits and reaming bits.

Use the best grinding tool

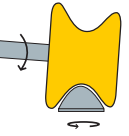
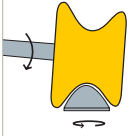
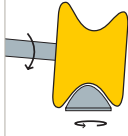
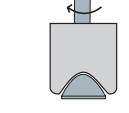
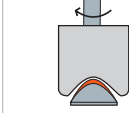
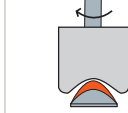
	New grinding tool	Half worn grinding tool	Worn grinding tool
Patented diamond grinding wheel			
Traditional grinding cup			
		Protrusion loss	



A useful tip: Use a Grind Matic grinding template, and you'll see when it's time for a grind.

Grinding solutions for every job site





Epiroc provides mobile and stationary grinding equipment for threaded, tapered, DTH- and COPROD button bits and integral rods with chisel inserts. Whatever the button profile or insert shape, we have the solution to match. Naturally, we also offer a full range of accessories and consumables, including grinding wheels, grinding cups and bit holders.

Check out our selection. We probably have the ideal machine for you.



Cemented carbide buttons.

Machine symbols

High voltage (AC).		Compressed air.		Working pressure. Unless otherwise stated, 7 bar is standard.		Low voltage (DC).	24V	Hydraulic oil	
--------------------	---	-----------------	---	---	---	-------------------	------------	---------------	---

Intensive

High frequency of grinding (full shift)



Boost your productivity

Grind Matic BQ3

Semi-automatic grinding machine for threaded and tapered button bits.

Grind Matic BQ3 is a fast, semi-automatic grinder specially designed for our profiled diamond grinding wheels, allowing you to precision-grind cemented carbide buttons and steel in the same operation. Grind Matic BQ3 is so easy to use that one operator can readily handle more than one machine at a time. To use Grind Matic BQ3, simply connect the machine to electricity and air.

The new high pressure flushing pump facilitates accurate flushing. This ensures that the Epiroc diamond grinding wheel is clean, which means a service life improvement of up to 50%! The ergonomics have also been improved thanks to the new adjustable handle, improved lighting and better service access. This makes the BQ3 easier to use and more efficient to operate.



Grinding machine

Grind Matic BQ3	Product no.
400 V 3-phase 50 Hz	87004800
230 V 3-phase 50 Hz	87004801
400 V 3-phase 60 Hz	87004803
230 V 3-phase 60 Hz	87004805
440 V 3-phase 50 Hz	87004806

Technical data

Air pressure, max.	7 bar (101.5 psi)
Air pressure, min.	5,5 bar (80 psi)
Air consumption	40 l/min
Voltage working lighting	24 V
Weight, excluding packaging	222 kg (490 lb)
Transport dimensions	L 1160 x W 1030 x H 1730 mm (3'9 5/8" x 3'4 1/2" x 5'8 1/8")

Grinding capacity

Maximum height of drill bit	200 mm (7 7/8")
Maximum diameter of drill bit	127 mm (5")
Minimum distance between buttons	3,5 mm (9/64")

A perfect machine for high productivity

- Grinds hundreds of bits per shift
- CE, WEEE, and RoHS approved
- Easy to use
- Helps you to spend more time on drilling
- Improves your bottom line
- Built by hand in Sweden

Accessories included in delivery

Allen key, 8 mm (1 piece)
Centering cup, 11 mm (1 piece)
Centering device (1 piece)
Grinding wheel, uncoated for centering
Protective goggles
Operator's instructions and spare parts list
Box wrench, 15 mm

Note: Grind Matic BQ3 must be completed with grinding wheels, centering cups (others than 11 mm), bit holders and indexing templates.

Intensive

High frequency of grinding (full shift)



A fast machine

Grind Matic BQ3-DTH

Semi-automatic grinding machine for DTH- and COPROD button bits. Can also be used for threaded and tapered button bits with optional accessories.

Grind Matic BQ3-DTH is a fast machine. And with speed comes greater efficiency. We've included a bit holder and an automatic centering arm. Combine these novel features with a more powerful grinding motor, as well as a fourfold increase in bit rotation speed, and you're looking at vastly superior grinding capacity. Grind Matic BQ3-DTH is designed with the driller in mind. Add to that a handy time relay for setting grinding time, a tiltable bit holder to help you handle heavier bits more easily, plus an electric locking device, and you'll find this is a highly rational grinding machine.

Moreover, Grind Matic BQ3-DTH is built to last. The spindle bearing is protected by a splashguard. And all electrical and pneumatic components are housed in separate cabinets on both sides of the machine, protecting them from dust, dirt and water.



Grinding machine

Grind Matic BQ3-DTH	Product no.
400 V 3-phase 50 Hz	87004900
230 V 3-phase 50 Hz	87004901
400 V 3-phase 60 Hz	87004903
230 V 3-phase 60 Hz	87004905
440 V 3-phase 50 Hz	87004906

Technical data

Air pressure, max.	7 bar (101,5 psi)
Air pressure, min.	5,5 bar (80 psi)
Air consumption	40 l/min
Voltage working lighting	24 V
Weight, excluding packaging	345 kg (760 lb)
Transport dimensions	L 1200 x W 1200 x H 1700 mm (3'11¼" x 3'11¼" x 5'6⅞")

Grinding capacity

Maximum height of drill bit	650 mm (2'1½")
Maximum diameter of drill bit	178 mm (7")
Minimum distance between buttons	3,5 mm (⅝")

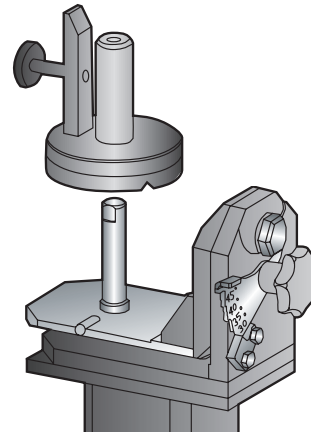

Auxiliary set (87003939) for use of tophammer bits in BQ3-DTH grinding machine.

Optional accessories

Auxiliary set for grinding threaded bits (exclusive bit holder and templates)

Product no.

87003939

Accessories included in delivery

Protective goggles
Operator's instructions and spare parts list
Box wrench, 15 mm
Allen key, 8 mm

Note: Grind Matic BQ3-DTH must be completed with grinding wheels, centring cups and bit holders.

Intermediate

Medium frequency of grinding (10 – 25 bits/day)



Grinding made easy

Grind Matic Manual B

Handheld portable grinding machine for threaded and tapered button bits.

Grind Matic Manual B is an air-powered grinding machine, equipped with diamond grinding wheels for spherical, ballistic and Trubbnos buttons. Mounted in a box fitted with wheels and handles, Manual B is mobile and easy to set up. A separate water tank provides efficient recirculated cooling.

Grinding couldn't be easier

By simply folding the box support legs and connecting the air hose and the hose to the water cooler container, you'll have the machine up and running in no time.

The handheld part of Manual B is a straight air-powered grinder specially designed for Epiroc diamond grinding wheels. The bit holder, driven by an air-powered motor, is fitted in the bottom of the box.

A steel spring is mounted in the profile of the grinding wheel where it functions as a centering finger, greatly simplifying the grinding operation.



Grinding machine	Product no.
Grind Matic Manual B	87001890

Technical data	
Air pressure, max.	7 bar (101,5 psi)
Air consumption	15 l/s
Coolant container	10 l
Weight, ex. packaging	55 kg (121,3 lb)
Weight, incl. packaging	90 kg (198,4 lb)
Transport dimensions	L 1200 x W 800 x H 850 mm (3'11¼" x 2'7½" x 2'9½")

Grinding capacity	
Max. bit skirt diameter	
Max. diameter, threaded bits	127 mm (5")
Max. diameter, retrace bits*	127 mm (5")
Max. diameter, tube drilling*	152 mm (6")

* Large clamping device necessary. Prod No. 87001930

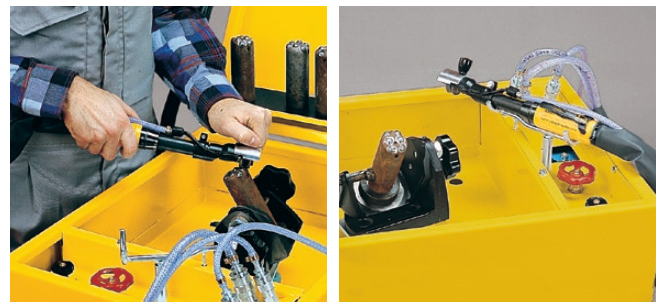

Optional accessories	Product no.
Set of 5 centring fingers	87004443

Accessories included in delivery

- Allen key, 4 mm
- Centering fingers (4 pcs)
- Hand-held grinder, 30 000 r/min
- Open end spanner, 14 mm (2 pcs)
- Protective goggles
- Operator's instructions and spare parts list

Note: Grind Matic Manual B must be completed with grinding wheels and bit holders.

Intermediate

Medium frequency of grinding (10 – 25 bits/day)



Smooth and swift

Grind Matic Manual B-DTH

Handheld portable grinding machine for DTH- and COPROD bits. Can also be used for threaded and tapered button bits with optional accessories.

Grind Matic Manual B-DTH is a hand-held grinder for grinding down-the-hole bits. Equipped with a few simple accessories, it also grinds threaded button bits. The machine is air-powered and uses Grind Matic diamond grinding wheels for grinding spherical, ballistic and Trubbnos button profiles.

The Manual B-DTH is mounted in a box fitted with wheels and handles. A separate water tank provides efficient recirculated cooling.

Smooth and swift operation

Simply connect your Manual B-DTH to air. Fill up water, and it's ready to use. The bit holder, driven by an air-powered motor, is mounted in the bottom of the box.

The hand-held part of Manual B-DTH is a straight, air-powered grinder specially adapted to our diamond grinding wheels. A steel spring is mounted in the profile of the grinding wheel where it functions as a centering finger, greatly simplifying the grinding operation.

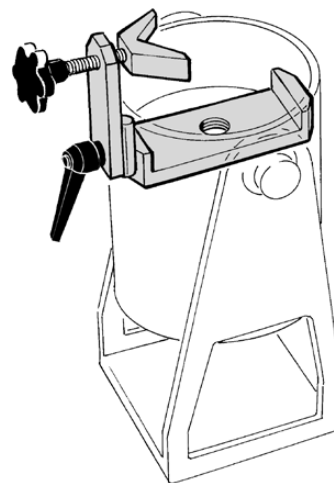

Clamping device for threaded bits (87002401) in Manual B-DTH grinding machine.

Grinding machine	Product no.
Grind Matic Manual B-DTH	87002300

Technical data	
Air pressure, max.	7 bar (101,5 psi)
Air consumption	15 l/s
Coolant container	10 l
Weight, ex. packaging	110 kg (253 lb)
Weight, incl. packaging	148 kg (326 lb)
Transport dimensions	L 1200 x W 800 x H 940 mm (3'11¼" x 2'7½" x 3'1")

Grinding capacity	
Max. height of drill bit	506 mm (17⅞")
Max. diameter of drill bit	203 mm (8")
Max. diameter of bit shank	170 mm (6¾")

Optional accessories	Product no.
Set of 5 centering fingers	87004443
Clamping device for threaded bits	87002401

Accessories included in delivery

Allen key, 5 mm
Allen key, 6 mm
Centering fingers (4 pcs)
Hand-held grinder, 30 000 r/min
Open end spanner, 14 mm (2 pcs)
Protective goggles
Operator's instructions and spare parts list

Note: Grind Matic Manual B must be completed with grinding wheels and bit holders.

Intermediate

Medium frequency of grinding (10 – 25 bits/day)

24V



Grinding has never been easier

Grind Matic RH3

Our Multi grip holder opens up your options to different types of bit designs for a complete range. From small tophammer bits to larger DTH and COPROD bits.

Grind Matic RH3 is a fully hydraulic powered grinding machine, designed to be attached to, and fit a wide range of drill rigs. With its low oil consumption, the machine can be used while drilling is in progress. It grinds cemented carbide buttons and the surrounding body steel in the same operation using a diamond coated grinding wheel. The machine has an automatic feeding device, which makes it simple to use and the centring function makes sure that the button is exactly positioned before grinding starts.



Grinding machine	Product no.
Grind Matic RH3	87005200

Rig brackets	Product no.
Kit for Epiroc cabin rigs	87005205
Kit for FlexiROC T35R rigs	87005206

Main bit holders	Product no.
Multi grip	87004360
Tophammer*	87004964

*Must be completed with thread specific bit holder. If you have chosen a bracket for Tophammer in the table on page 18, make sure you complete it with a bit holder in the table below.

Oil filter	Product no.
Filter + bracket	87004952

Technical data	
Rec. oil pressure, min-max	150-260 bar
Oil consumption	13 l/min
Cooling liquid consumption	Max 20 l/h
Voltage	24 VDC
Current	6 A
IP class	65
Working temperature	-25°C – +50°C
Speed, spindle	10 500 rpm
Weight	85 kg

Grinding capacity

Max. distance between bit holder and grinding wheel	230 mm
Drill bit diameters	35 – 165 mm
Max. grip size	110 mm
Min. distance between buttons	3,5 mm

Optional accessories

Optional accessories	Product no.
Centering fingers, S (3 pcs) <11 mm	87004868
Centering fingers, M (3 pcs) 10-14 mm	87004871
Centering fingers, L (3 pcs) >13 mm	87004872
Splash guard	87004423
Belt	87004944
Gear kit (gears + belt)	87004791
Oil filter insert (10 micron)	87004953

Recommended grease: Mobil SHC100 or SKF LGGB2.

Accessories included in delivery

Allen key, 4 mm
Centering fingers (3 pcs)
Locking pin (1 pcs)
Extractor
Spare screws (4 pcs)
Protective goggles
Operator's instructions and spare parts list

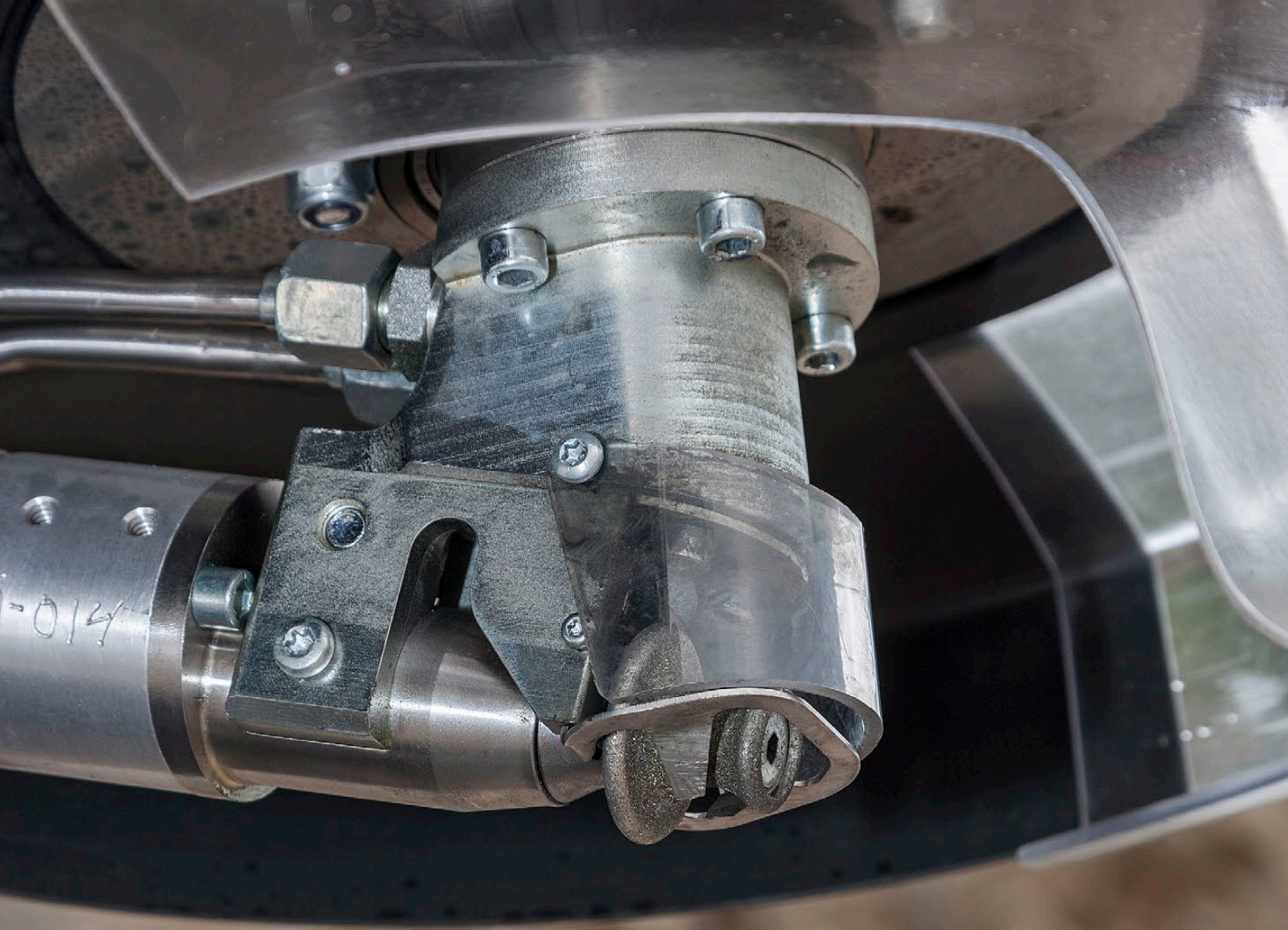

014





EMERGENCY STOP

EMERGENCY STOP

HYDROSCAND EREFLEX 1 E

Take care of your working environment!

It is important that you keep your working environment in good shape and keep regular controls of the working process to obtain the best performance possible. This also prevents damage on your machines and cuts your operating costs. Whatever you need for a profitable production, Epiroc can offer the perfect grinding solution for you.

Benefits with care for optimal regrinding:

- Improved safety!
- Higher performance and better production
- Lower repair costs
- Reduced air consumption
- Less wear and tear on your equipment



Accessories and consumables

Bit holders for button bits

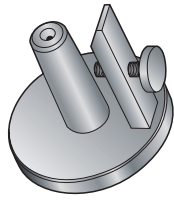

Bit holder type A
For Grind Matic BQ3. Can also be used for BQ3-DTH with optional accessories.

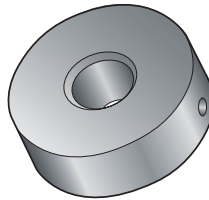

Bit holder type B
For Grind Matic BQ3-DTH and Manual B-DTH.

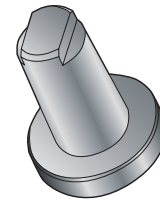

Bit holder type C
For Grind Matic Manual B and Manual B-DTH

Type of bit holder	Type of bit	Product no
A	Threaded bits	
	R25	87003475
	R28	87003476
	R32	87003477
	R38	87004686
	T35	87005089
	T38	87004687
	T45	87003479
	T51 and retrac	87003521
	T-WiZ60 (Note 1)	87005052
	GT-60 (Note 1)	87005085
	Magnum SR28	87003960
	Magnum SR32	87003962
	Magnum SR35	87003956
	TC35	87004685
	TC42	87004641
	Tube bits	
	ST58	87003522
	ST68	87003523
	Tapered bits	
	7° taper	87003524
	12° taper	87003525
	Reaming bits	
	64, 76 and 89 mm	87003526
	89, 102 and 127 mm	87003527
	Guide bits	
	R32	87003992
	SR35	87004056

Type of bit holder	Type of bit	Product no
B	DTH- and COROD bits	
	DHD 3.5	87004514
	DHD 340	87002391
	DHD 350	87002390
	DHD 360	87002389
	TD 40	87004604
	RC45.RC50	87004605
	QL 50	87004033
	QL 60	87004002
	COPROD 76	87004414
	COPROD 89	87003155
	COPROD 102	87004415
	COPROD 127	87002396
	COPROD 140	87004518
	T60 (Note 1)	87004562
	COP M6	87004789

Type of bit holder	Type of bit	Product no
C	Threaded bits	
	R25	87000792
	R28	87000793
	R32	87000794
	R35	87003360
	R38	87000795
	T38	87000795
	T45	87000796
	T51	87000802
	Magnum SR28	87003961
	Magnum SR35	87003957
	Tapered bits	
	7° taper	87001044

Note 1: Must be used together with clamping device 87004777 (observe max bit height).

Centering cups

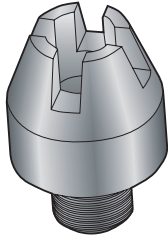

For Grind Matic
BQ3 and BQ3-DTH.

Button size, mm	Product no.
7	87001040
8	87000842
9	87001047
10	87001041
11	87000840
12	87001042
12,7	87000839
13	87001385
14	87001043
14,5	87001443
15	87001386
16	87001387
18	87003943
19	87003944

Grinding wheels for steel removal

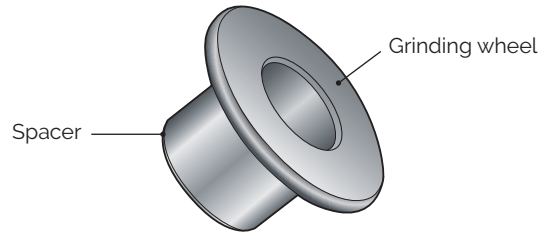

For Grind Matic
BQ3 and BQ3-DTH.

Type	Product no.
Grinding wheel	87001530
Spacer for 10 mm button	87001631
Spacer for 11 mm button	87001632
Spacer for 12 mm button	87001633
Spacer for 13 mm button	87001634
Spacer for 14 mm button	87001635

Note: All grinding wheels have an inner diameter of 12 mm.

Grinding templates – Integral rods and bits



For button bits.

Dimension, mm	Product no.
Button bits, spherical	
7 – 14,5	87005282
11 – 22	87005284
Button bits, Trubbnos	
6 – 12	87005287
12,7 – 19,1	87005288
Button bits, ballistic	
7 – 14,5	87005283
11 – 22	87005285



Diamond grinding wheels for button bits – for all Grind Matic BQ and Manual B machines

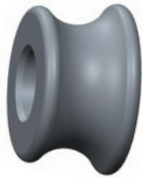

Grinding wheel for spherical buttons.

Diameter, mm	Product no.
Grinding wheels – Spherical buttons	
7	87004554
8	87004555
9	5697001211
10	87003970
11	87003971
12	87003972
13	87003973
14	87001025
15	87001384
16	87001027
18	87003964
19	87003966

Note: These grinding wheels have an inner diameter of 12 mm.



Grinding wheel for Trubbnos buttons.

Diameter, mm	Product no.
Grinding wheels – Trubbnos buttons	
9	87005337
10	87005338
11	87005339
12	87005340
12,7	5697001024
14,5	5697001025
15,8	5697001026
19,1	5697001210

Note: These grinding wheels have an inner diameter of 12 mm.



Grinding wheel for ballistic buttons.

Diameter, mm	Product no.
Grinding wheels – Ballistic buttons	
7	87004556
8	87004557
9	87003974
10	87003975
11	87003976
12	87003977
13	87003413
14	87003414
15	87003415
16	87003416
18	87003965
19	87003967

Note: These grinding wheels have an inner diameter of 12 mm.

Diamond grinding wheels for button bits – for Grind Matic RH3



Grinding wheel for spherical buttons.

Diameter, mm	Product no.
Grinding wheels – Spherical buttons	
8	87005032
9	87005033
10	87005049
11	87004851
12	87005050
12,7	87004852
13	87004848
14,5	87004853
15,8	87004854
19,1	5697002880

Note: These grinding wheels have an inner diameter of 10 mm.



Grinding wheel for Trubbnos buttons.

Diameter, mm	Product no.
Grinding wheels – Trubbnos buttons	
9	87004809
10	87004810
11	87004811
12	87004812
12,7	87004813
14,5	87004814
15,8	87004815
19,1	87004816

Note: These grinding wheels have an inner diameter of 10 mm.



Grinding wheel for ballistic buttons.

Diameter, mm	Product no.
Grinding wheels – Ballistic buttons	
8	87005034
9	87005035
10	87005036
11	87004855
12	87005051
12,7	87004856
13	87004849
14,5	87004857
15,8	87004858

Note: These grinding wheels have an inner diameter of 10 mm.

Diamond grinding cups for Grind Matic HG



Grinding cup for spherical buttons.



Grinding cup for ballistic buttons.



Grinding cup for steel removal.



Grinding cup for Trubbnos buttons

Diameter, mm	Product no.
Grinding cups – Spherical buttons	
7	87005110
8	87005111
9	87005112
10	87005113
11	87005114
12	87005115
13	87005116
14	87005117
15	87005118
16	87005119
18	87005120
19	87005121
20	87005122
22	87005123
25	87005124

Diameter, mm	Product no.
Grinding cups – Ballistic buttons	
7 B	87005130
8 B	87005131
9 B	87005132
10 B	87005133
11 B	87005134
12 B	87005135
13 B	87005136
14 B	87005137
15 B	87005138
16 B	87005139

Diameter, mm	Product no.
Grinding cups – Steel removal	
SG 7 – 8	87005150
SG 9 – 10	87005151
SG 11 – 12	87005152
SG 13 – 14	87005153
SG 15 – 16	87005154
SG 17 – 18	87005155
SG 19 – 20	87005156
SG 21 – 22	87005157

Diameter, mm	Product no.
Grinding cups – Trubbnos buttons	
9 T	87005160
10 T	87005161
11 T	87005162
12 T	87005163
12.7 T	87005164
14.5 T	87005165
15.8 T	87005166
19.1 T	87005167

Grinding stick

Optimize your grinding products by using our grinding stick. Great for opening, cleaning, reshaping of grinding cups and grinding wheels to keep its maximum performance.



Grinding stick

Silicon Carbide Abrasive

Description	Product no.	Dim.
Grinding stick	87002810	150 x 17

Air line accessories

Any pneumatic machine without built-in lubrication needs a separate lubricator to ensure that all moving parts are continuously covered with a film of oil.

Epiroc Grind Matic lubricators are designed to work in any position, horizontal, vertical or upside-down.

This secures a continuous oil supply to protect your machine. FY1100 is designed to work with mineral oil and an air flow between 8–15 liter/second. Hose diameter on the lubricator is 25 mm.

Accessories like air hoses, claw couplings, valves and hose clamps are also available in our assortment.



Lubricator mini.

Lubricators

Description	Product no.	Oil volume	Connection
Lubricator mini (max. 8 bar)	87002750	0,05 l	¼" – ¼" coupling

Grinding hints

The rate of bit wear depends on the rock formation, and is highest in rocks with a high quartz content. A suitable grinding interval should be determined according to the rate of bit wear. It is more economical to regrind too early rather than to suffer poor penetration rate and risk damaging the drill bit through overdrilling. Following are a few tips on caring for your drill bits.

When to regrind

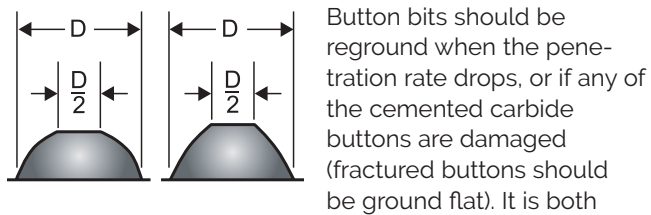

practical and economical to redress the buttons when the wear flat reaches about 40 – 50% of the diameter of the button.

Look out for “snake skin”

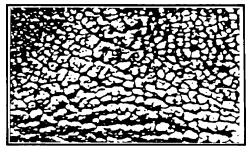

If microscopic fatigue cracks – so-called “snake skin” – begin to appear on the cemented carbide buttons, the cracks must be ground away. In any event, bits should be reground after 300

metres of drilling at the most. This should be done even if there are no visible signs of wear and the penetration rate continues to be good. If snake skin is not removed, the cracks will deepen and ultimately result in button fracture.

Do not grind away too much cemented carbide

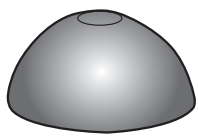

Do not grind too much on the top of the buttons. Let a few millimetres of the wear flat remain on top of the button.

Always grind broken buttons flat

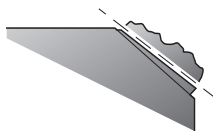

A drill bit can remain in service as long as the gauge buttons maintain the diameter of the bit. Fractured buttons must always be ground flat to prevent chips of cemented carbide from damaging the other buttons.

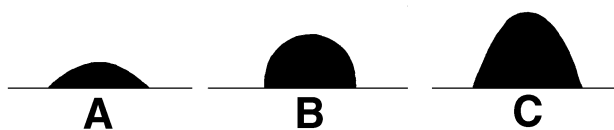

A = Incorrect grinding result – too little protrusion
 B = Correct grinding result – spherical button
 C = Correct grinding result – ballistic button

Avoid grinding the perimeter

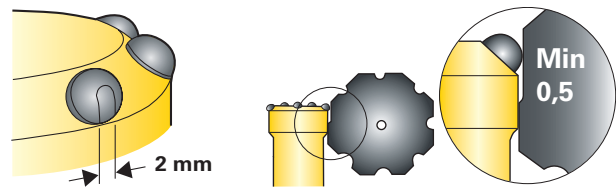

Gauge button anti-taper has to be removed by grinding, although excessive reduction of the bit diameter should be avoided. Leave about 2 mm of the wear flat.

If necessary, remove some of the bit-body steel below the gauge buttons, so that a clearance (taper) of 0.5 mm is maintained. If the flushing holes start to deform, open them up with the aid of a rotary burr or steel file.

Drill bits with two button sizes

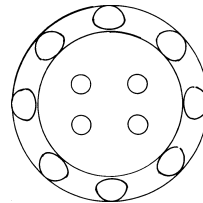

When grinding drill bits with two different button sizes, be sure to use a grinding wheel with appropriate dimensions for the button that are to be ground.

Overdrilled bits

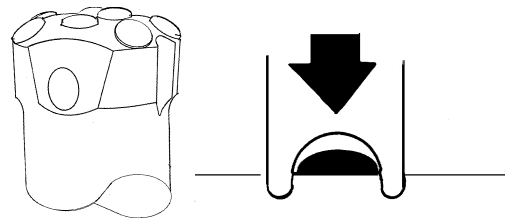

When a drill bit has been severely overdrilled, it can be difficult to get the centering fingers to guide the grinding wheel around the cemented carbide buttons. In this case, stop the rotation of the drill bit and grind a few grooves into the body steel around the button. To do this, press the grinding wheel straight down over the button. Repeat the above procedure a few times at different angles.

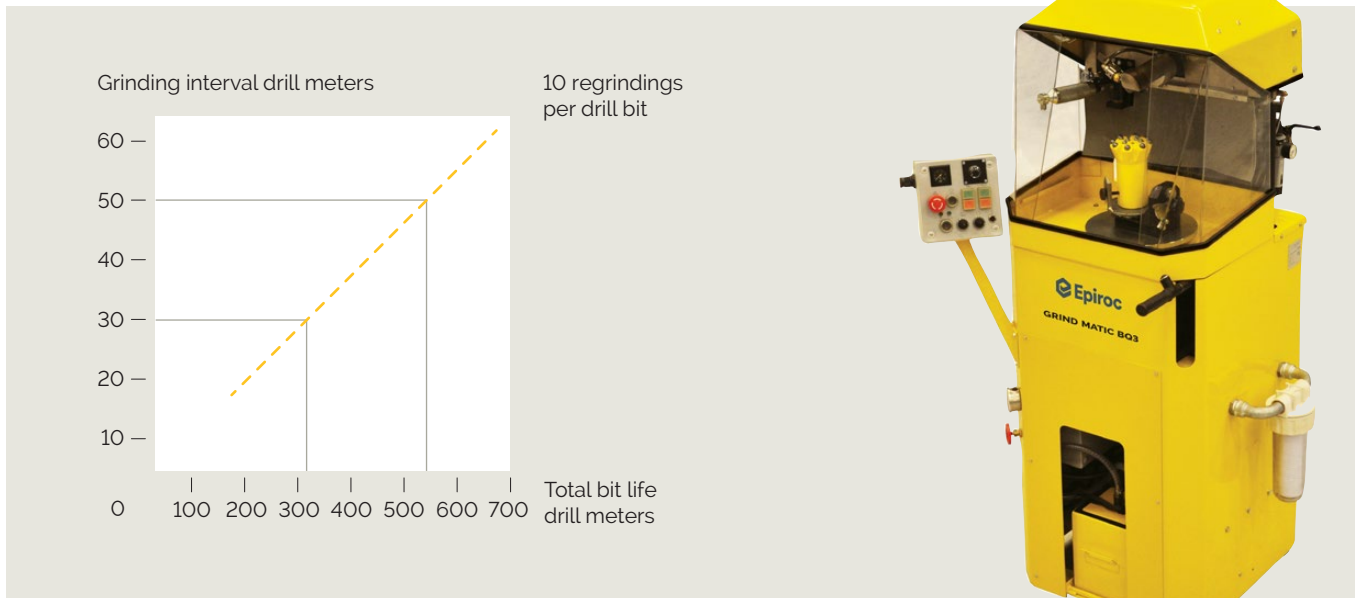

Figure 1: Typical bit life grinding at different intervals. The Epiroc Grind Matic BQ3 grinding machine can handle bits up to 127 mm in diameter.

Know your drilling

Bit service life

It is a well-established fact that the service life of a button bit increases considerably if the cemented carbide buttons are ground. Nowadays, it has become extremely important to grind button bits at proper intervals to extend the service life of the rock drilling tool, maintain penetration rate and costs, and drill straight holes.

With so many parameters involved, it is difficult to estimate bit service life. First, a proper grinding interval must be established, preferably at the stage when the button has a wear flat of 40 – 50% of the button diameter. When the number of drilled meters to reach this stage has been established, then the calculation of bit life can be made by multiplying the number of times it can be reground.

As a general rule, a bit can be reground 10 times; smaller bits may achieve slightly less than this figure, while larger bits may achieve more. So, if the grinding interval has been established as 60 drilled meters, then the average bit life will be 660 drilled meters (see Figure 1).

If a bit is overdrilled and the wear flat is more than half of the button diameter, there is a tendency towards cracked buttons. There is always a sharp edge created on the button, and this becomes sharper the more the

bit is overdrilled. This sharp edge, especially on ballistic buttons, is very brittle. Once the edge cracks, pieces of cemented carbide break away and circulate in the hole, causing secondary damage to the buttons.

When a bit doesn't show any visible wear flat, it may be suffering from micro cracks on the cemented carbide surface. This is known by the term "snake skin" and can be clearly seen when using a magnifier. In this case, the surface has to be ground away; otherwise the micro cracks lead to more severe damage on the buttons. Likewise, buttons that protrude too much must be ground down to avoid damage (see Figure 2).

In all rock excavation operations, the cost is usually expressed in cost per drilled meter (cost/dm), in cost per cubic meter (cost/m³), or in cost per tonne (cost/t). The cost to produce a hole depends on how fast it can be drilled and how many tools will be consumed. The cost to produce a cubic meter of rock is dependent upon the cost of the hole and the cost of blasting.

If the blasthole is of poor quality, then more explosives will be consumed in blasting the rock. Worn bits very often give a poor quality hole with a greater risk of deviation.

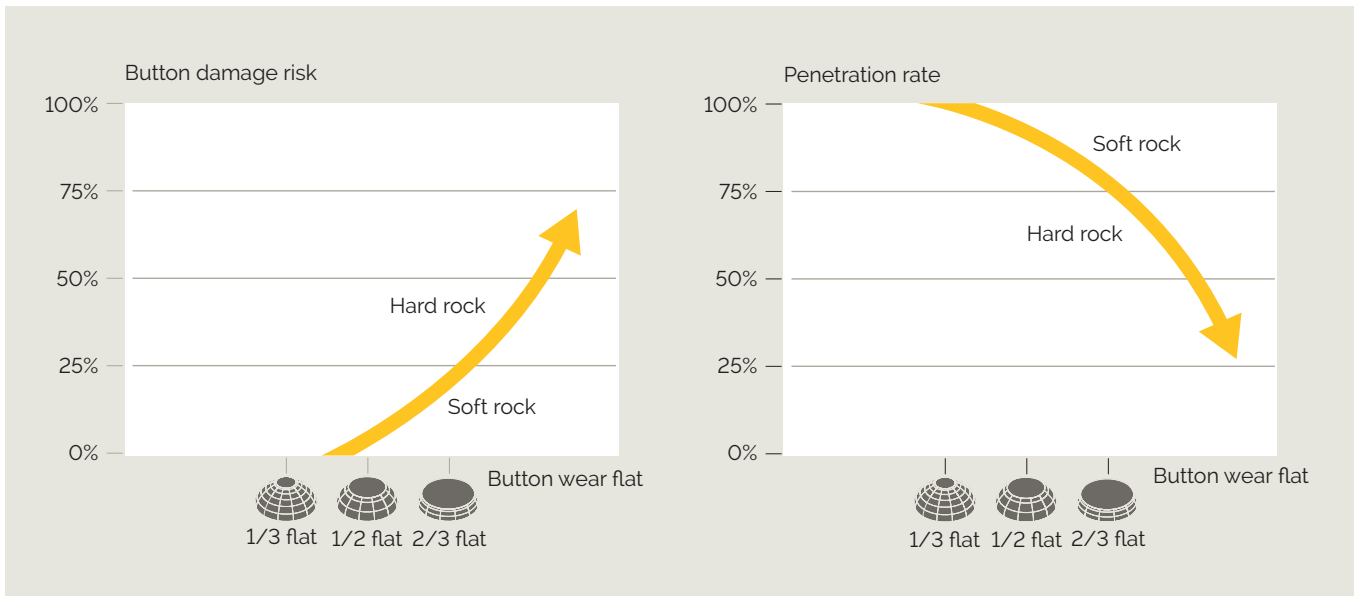

Figure 2: Risk of total loss when a bits is overdrilled.

Figure 3: Penetration rate drops as the button profiles flatten.

Penetration rate

When the right bit has been chosen for the rock condition, it will provide maximum penetration rate along with acceptable hole straightness. In rock conditions like Swedish granite with a compressive strength of around 200 MPa, the bit gets a wear flat after just 10 – 20 drill meters accompanied by a small drop in penetration rate. When it has a wear flat equivalent to 40 – 50% of the button diameter, the penetration will have dropped by 5%. If the bit is used further until it has a two thirds wear flat, the penetration will have dropped more than 30% (see Figure 3).

When a bit has a heavy wear flat, it tends to deviate, and by the time it reaches the bottom of the hole, it will have deviated far more than planned. As a result, the blast will produce short pull. In contour hole drilling, it is of utmost importance that the holes are straight. If the holes deviate, the tunnel walls will be uneven, which increases the risk for overbreak or underbreak.

Rock formations with different layers and joints are often characterized by heavy hole deviation, putting extra stress on the remaining rock tools in the drill string. A sharp bit always cuts better and will prevent both deviation and its disadvantages.



Indexing templates

Grind Matic BQ3

Drill bit		Indexing template
Product no.	Product code	
R25		
90510448	102-5033-17,39-20	87003484
90510274	102-5033-17-67,39-20	87003484
90514118	102-5033-41-67,39-20	87004037
90505181	102-5035-27,39-20	87003483
90509723	102-5035-27-67,39-20	87003483
90505295	102-5037-27,39-20	87003483
90513899	102-5037-99,38-20	87004741
90513900	102-5037-99-67,39-20	87004741
90505179	102-5038-27,39-20	87003483
90505180	102-5038-27-67,39-20	87003483
90515669	102-5038-34-66,39-20	87004741
90505175	102-5041-27,39-20	87003499
90505176	102-5041-27-67,39-20	87003499
90505145	102-5045-27,39-20	87003480
90513912	102-5048-27,39-20	87003499
90505353	102-5051-27,39-20	87003485
90510208	102-5045-56,39-20	87003482
90513912	102-5048-27,39-20	87003499
90505353	102-5051-27,39-20	87003485
R28		
90505296	107-5037-27,39-20	87003483
90505177	107-5038-27,39-20	87003483
90505178	107-5038-27-67,39-20	87003483
90505173	107-5041-27,39-20	87003499
90505174	107-5041-27-67,39-20	87003499
90505169	107-5043-27,39-20	87003499
90509467	107-5045-37,39-20	87003481
SR28		
90514200	125-5033-17,39-20	87003484
90029167	125-5033-27-67-99,39-20	87004741
90514117	125-5033-41,39-20	87004037
90514137	125-5033-41-67,39-20	87004037
90029410	125-5034-27-67,39-20	87004741
90514322	125-5035-27,39-20	87003483
90514102	125-5035-27-67,39-20	87003483
90514167	125-5037-99,39-20	87003483
90003625	125-5037-99-67,39-20	87004741
90514282	125-5038-27,39-20	87003483
90516334	125-5038-41-67,39-20	87004741
90029184	125-5040-27,39-20	87004741
90515379	125-5041-27,39-20	87005309
90515543	125-5042-27,39-20	87005309
90029307	125-5043-27,39-20	87005309
90514507	125-5045-27,39-20	87003480
90516422	125-5045-37-67,39-20	87003481
90003626	125-5048-37,39-20	87003486
90514793	125-5051-27,39-20	87003485
90029897	125-5076-42-24,57-20	87003951

Drill bit		Indexing template
Product no.	Product code	
R32		
90505171	103-5041-27,39-20	87003499
90505172	103-5041-27-67,39-20	87003499
90510744	103-5041-34-67,39-20	87003492
90505164	103-5043-27,39-20	87003499
90510769	103-5043-37-67,39-20	87003486
90029544	103-5043-39-67,56-12	87003495
90504373	103-5045-27,39-20	87003480
90512011	103-5045-27-67,39-20	87003480
90029189	103-5045-34-66,56-20	87003492
90514111	103-5045-37-66,39-20	87003481
90509460	103-5045-37-67,39-20	87003481
90504401	103-5045-39,39-20	87003488
90029325	103-5045-39,56-20	87003488
90514540	103-5045-39-67,39-20	87003488
90029629	103-5045-39-67,56-12	87003488
90029358	103-5045-39-67,56-20	87003488
90509461	103-5048-37,39-20	87003486
90514135	103-5048-37-66,39-20	87003481
90029166	103-5048-37-66-99,39-20	87003481
90509464	103-5048-37-67,39-20	87003486
90515773	103-5048-39-67,39-20	87004754
90510450	103-5051,39-20	87003496
90504566	103-5051-27,39-20	87003485
90029797	103-5051-27-20,56-20	87005311
90029845	103-5051-27-20-45-67,39-20	87005311
90029191	103-5051-34-66,56-20	87005314
90509465	103-5051-37,39-20	87003481
90510836	103-5051-37-45-67,39-20	87003481
90514136	103-5051-37-66,39-20	87003481
90509466	103-5051-37-67,39-20	87003481
90003532	103-5051-37-67-99,39-20	87004478
90029192	103-5051-39-67,56-20	87004314
90510795	103-5054-24-45-67,39-20	87003493
90509481	103-5054-37-67,39-20	87003486
90510453	103-5057-20,39-20	87003495
90510454	103-5057-20-67,39-20	87003495
90514267	103-5057-37-45,49-20	87003495
90515503	103-5057-37-54-67,39-20	87003495
90514440	103-5057-37-66,39-20	87003481
90514414	103-5057-54,39-20	87004775
90510303	103-5064,49-20	87003489
90514983	103-5064-37-66,49-20	87003495
90510381	103-5064-45,49-20	87003489

Grind Matic BQ3

Drill bit		Indexing template
Product no.	Product code	
R32		
90510327	103-5064-67,49-20	87003489
90510353	103-5076,49-20	87003493
90514373	103-5076-42-24,49-20	87003951
90029885	103-5076-42-24,57-20	87003951
90510821	103-5076-42-24-67,49-20	87003951
90029882	103-5089-42-24,57-20	87003953
90029891	103-5089-42-24-70,57-20	87003953
90029889	103-5102-42-24,57-20	87003953
90029884	103-5102-42-24-70,57-20	87003952
90029896	103-5127-42-24,57-20	87004775
90510308	103-6051-45,49-20	87003487
90514633	103-6051-45-67,49-20	87003487
90515761	103-6051-67,39-20	87003487
90510328	103-6064,49-20	87003487
90510364	103-6064-45,49-20	87003487
90510414	103-6064-45-67,49-20	87003487
90510504	103-6076-45,49-20	87003498
90029913	103-9102-40,49-20	87003560
90029320	103-9102-45-A,49-20	87003560
SR32		
90514501	126-5038-27-67,39-20	87004741
90516483	126-5041-37-67,39-20	87003486
90515721	126-5048-37-67,39-20	87003486
90514954	126-5064-67,49-20	87003489
90029898	126-5076-42-24-70,57-20	87003559
90514503	126-6051,49-20	87003487
SR35		
90513844	128-5043-27,39-20	87003499
90515576	128-5043-27-67,39-20	87003499
90516547	128-5043-39-67,39-20	87003495
90513846	128-5045-37-30-67,39-20	87003481
90513839	128-5045-37-67,39-20	87003481
90514720	128-5045-39-67,39-20	87003488
90029368	128-5045-39-67-S,39-20	87003488
90029303	128-5045-39-S,39-20	87003488
90514709	128-5048-37-67,39-12	87003486
90514150	128-5048-39,39-20	87004754
90003607	128-5048-39-67,39-20	87004635
90029302	128-5048-39-S,39-20	87004754
90029905	128-5051-24-45-S,39-20	87004464
90514595	128-5051-24-45-67,39-20	87003493
90513842	128-5051-37-67,39-20	87003481
90514610	128-5051-39,39-06	87003486

Drill bit		Indexing template
Product no.	Product code	
SR35		
90514220	128-5054-24-45-67,39-20	87004464
90513870	128-5064-67,49-20	87003489
90029892	128-5076-42-24-70,57-20	87003951
90029890	128-5089-42-24,57-20	87003953
90029881	128-5089-42-24-70,57-20	87003953
90029807	128-5102-42-24,57-20	87003953
90029808	128-5102-42-24-70,57-20	87003953
90516569	128-6054-45-67,39-20	87004754
90516250	128-6064,49-06	87003487
90515626	128-6064-45-67,49-20	87003487
T35		
90029204	133-5048-37-67,39-20	87003486
90029827	133-5048-39-70,37-20	87005313
90029823	133-6051-44-70,37-20	87003559
90029822	133-6054-44-70,37-20	87003559
90029786	133-6057-44-70,37-20	87003559
90029785	133-6064-21-44-70,57-20	87003487
TC35		
90516336	169-5048-37-67,39-20	87003486
90003692	169-5051-37-67,39-20	87003486
90029029	169-5051-39-99,39-20	87003486
90029770	169-6051-45,39-20	87003487
90516337	169-6051-45-67,49-20	87003487
90029771	169-6054-45,39-20	87003487
90516423	169-6054-45-67,49-20	87003487
90516564	169-6054-67,39-20	87004754
90029298	169-6057-45,39-20	87003487
90516536	169-6057-45-67,39-20	87003487
90029299	169-6064-48-45,49-20	87003985
90516424	169-6064-48-45-67,49-21	87003985
90003723	169-5102-42-24,49-20	87003952
90029572	169-9127-51,49-20	87005315
R38		
90510304	104-5064,49-20	87003489
90510318	104-5076,49-20	87003493
T38		
90029693	135-5064,57-20	87003953
90029753	135-5064-44,57-20	87003953
90029694	135-5064-70,57-20	87003953
90029689	135-5076,57-20	87004433
90029688	135-5076-44,57-20	87004433
90029752	135-5076-79-99,57-20	87005315
90029684	135-5089,57-20	87004434
90029867	135-5089-44,57-20	87004434
90029923	135-5089-47-70,57-20	87004432
90029788	135-5102,57-20	87004775
90029789	135-5102-42-24,57-20	87003953
90029920	135-5102-47-70,57-20	87004432

Grind Matic BQ3

Drill bit		Indexing template
Product no.	Product code	
T38		
90029784	135-5127-42-24,57-20	87004775
90029783	135-5127-42-24-70,57-20	87004775
90029712	135-6064-21,57-20	87003487
90029467	135-6064-21-44,57-20	87003487
90029466	135-6064-21-44-70,57-20	87003487
90029713	135-6064-21-70,57-20	87003487
90029718	135-6070-21,57-20	87003953
90029690	135-6070-21-44,57-20	87003953
90029691	135-6070-21-44-70,57-20	87003953
90029715	135-6076-21,57-20	87003953
90029686	135-6076-21-44,57-20	87003953
90029687	135-6076-21-44-70,57-20	87003953
90029717	135-6076-21-70,57-20	87003953
90029757	135-6076-44-70,57-12	87003953
90029686	135-6076-44-70,57-20	87003953
90029714	135-6076-70,57-20	87003953
90029716	135-6089-21,57-20	87004432
90029681	135-6089-21,44,57-20	87004432
90029719	135-6089-21-70,57-20	87004432
90029682	135-6089-44-70,57-20	87004432
90029787	135-9127-51,57-20	87003500
TC42B		
90029863	172-6054-67,37-20	87004754
90029862	172-6057-67,37-20	87004754
90029844	172-6064-48-45-67,57-20	87003985
T45		
90029371	136-5076,57-20	87004433
90029370	136-5076-44,57-20	87004433
90029367	136-5089,57-02	87004434
90029366	136-5089-44,57-20	87004434
9029927	136-5089-47-70,57-20	87004432
90029404	136-5102,57-20	87004775
90029403	136-5102-44,57-20	87004775
90029925	136-5102-47-70,57-20	87004432
90029607	136-5127-42-24,57-20	87004775
90029606	136-5152-42-24,57-20	87004775
90029605	136-5152-42-24-67,57-20	87004775
90029614	136-6066-21-44-70,57-20	87003487
90029395	136-6070-21-44,57-20	87003953
90029394	136-6070-21-44-70,57-20	87003953
90029409	136-6070-21-70,57-20	87003953
90029120	136-6070-44-67,49-20	87003832
90510479	136-6070-45,49-20	87003559
90510385	136-6070-45-67,49-20	87003559
90510480	136-6070-67,49-20	87003559
90029377	136-6076-21,57-20	87003953
90029357	136-6076-21-44,57-20	87003953
90029737	136-6076-21-44-70,57-12	87003953
90029354	136-6076-21-44-70,57-20	87003953

Drill bit		Indexing template
Product no.	Product code	
T45		
90029835	136-6076-21-44-70-99,57-20	87003953
90029351	136-6076-21-70,57-20	87003953
90029376	136-6076-44-70,57-20	87003953
90029833	136-6076-44-70-99,57-20	87003953
90029352	136-6076-70,57-20	87003953
90029615	136-6083-44-70,57-20	87004432
90029360	136-6089-21,57-20	87004432
90029364	136-6089-21-44,57-20	87004432
90029362	136-6089-21-44-70,57-20	87004432
90029363	136-6089-21-70,57-20	87004432
90029366	136-6089-44,57-20	87004434
90029365	136-6089-44-70,57-20	87004432
90029840	136-6089-44-70-99,57-20	87004432
90029361	136-6089-70,57-20	87004432
90029408	136-6102-21,57-20	87004435
90029413	136-6102-21-44,57-20	87004435
90029412	136-6102-21-44-70,57-20	87004435
90029405	136-6102-21-70,57-20	87004435
90029411	136-6102-44-70,57-20	87004435
90029407	136-6102-70,57-20	87004435
90029601	136-6115,57-20	87003952
90029602	136-6115-44,57-20	87003952
90029603	136-6115-70,57-20	87003952
90029604	136-6127-21,57-20	87003953
90029802	136-9127-51,57-20	87003500
T51		
90029417	137-5089,57-20	87004434
90029402	137-5089-44,57-20	87004434
90029917	137-5089-47-70,57-20	87004432
90029425	137-5102,57-20	87004775
90029424	137-5102-44,57-20	87004775
90029918	137-5102-47-70,57-20	87004432
90029432	137-5115,57-20	87004775
90029429	137-5115-44,57-20	87004775
90029444	137-5127,57-20	87004775
90029439	137-5127-44,57-20	87004775
90029766	137-5152-42-24,57-20	87004775
90029733	137-6076-21,57-20	87003953
90029731	137-6083-44,57-20	87004432
90029419	137-6089-21,57-20	87004432
90029415	137-6089-21-44,57-20	87004432
90029414	137-6089-21-44-70,57-20	87004432
90029418	137-6089-21-70,57-20	87004432
90029416	137-6089-44-70,57-20	87004432
90029420	137-6089-70,57-20	87004432
90029734	137-6092-44-70,57-20	87003560
90029969	137-6095-44-70,57-20	87003560
90029400	137-6102-21,57-20	87004435
90029423	137-6102-21-44,57-20	87004435

Grind Matic BQ3

Drill bit		Indexing template
Product no.	Product code	
T51		
90029422	137-6102-21-44-70,57-20	87004435
90029399	137-6102-21-70,57-20	87004435
90029057	137-6102-44,49-12	87003952
90029421	137-6102-44-70,57-20	87004435
90029398	137-6102-70,57-20	87004435
90029438	137-6115-21,57-20	87003952
90029428	137-6115-21-44,57-20	87003952
90029401	137-6115-21-44-70,57-20	87003952
90510826	137-6115-21-45,49-20	87003750
90029434	137-6115-21-70,57-20	87003952
90029436	137-6115-70,57-20	87003952
90029427	137-6127-21,57-20	87003953
90029437	137-6127-21-44,57-20	87003953
90029433	137-6127-21-44-70,57-20	87003953
90029431	137-6127-21-70,57-20	87003953
90029435	137-6127-44-70,57-20	87003953
90029430	137-6127-70,57-20	87003953
90029735	137-6140-21,57-20	87004571
90029736	137-6152-21,57-20	87004572
T-WIZ60		
90029781	158-5095-44-99,57-20	87004775
90029700	158-5115-21-44,57-20	87004775
90029111	158-6092-21-44-67,49-20	87003832
90029711	158-6092-21-70,57-20	87003560
90029705	158-6095-21-44,57-20	87003560
90029701	158-6095-21-44-70,57-20	87003560
90029447	158-6102-21,57-20	87004435
90029450	158-6102-21-44,57-20	87004435
90029449	158-6102-44-70,57-20	87004435
90029695	158-6115-21,57-20	87003952
90029698	158-6115-21-44,57-20	87003952
90029696	158-6115-21-44-70,57-20	87003952
90029853	158-6121-44,57-20	87003500
90029707	158-6127-21,57-20	87003953
90029670	158-6127-21-44,57-20	87003953
90029672	158-6127-21-44-70,57-20	87003953
90029668	158-6140-21-44,57-20	87004571
90029751	158-6140-21-44-70,57-20	87004571
90029662	158-6152-21,57-20	87004572
90029664	158-6152-21-44,57-20	87004572
ST thread TDS (ST58)		
90029894	151-5152-42-24,57-20	87004775
90029709	151-6089-21,57-20	87004432
90029953	151-6089-21-35,57-20	87004432
90029656	151-6089-21-35-70,37-20	87004432
90029710	151-6102-21,57-20	87004435
90029651	151-6102-35-70,57-20	87004435
90029658	151-6115-21-35-70,57-20	87003952

Drill bit		Indexing template
Product no.	Product code	
TDS (ST68)		
90029868	152-5102-21-24,57-20	87004435
90029732	152-6102-21,57-20	87004435
90029725	152-6102-21-70,57-20	87004435
90029678	152-6102-35-70,57-20	87004435
90514048	152-6102-43-67,49-20	87004512
90029795	152-6102-43-70,57-20	87004512
90029673	152-6115-21-35,57-20	87003952
90029674	152-6115-35-70,57-20	87003952
90029728	152-6127-21,57-20	87003953
90029750	152-6152-21,57-20	87004572
90029791	152-9152-102,57-20	87003560
Dome bits		
90514373	103-5076-42-24,49-20	87003951
90510821	103-5076-42-24-67,49-20	87003951
90510843	103-5089-42-24,49-20	87003955
90510820	103-5089-42-24-67,49-20	87003955
90510781	103-5102-42-24-67,49-20	87003955
90513779	103-5127-42-24,49-20	87003954
90515258	125-5076-42-24,49-20	87003951
90514502	126-5076-42-24-67,49-20	87003951
90515257	126-5102-42-24,49-20	87003952
90515831	127-5102-42-24,49-20	87003952
90513848	128-5089-42-24,49-20	87003955
90513849	128-5089-42-24-67,49-20	87003955
90513850	128-5102-42-24,49-20	87003955
90513851	128-5102-42-24-67,49-20	87003955
90514219	128-5127-42-24,49-20	87004775
90003723	169-5102-42-24,39-20	87003952
90029607	136-5127-42-24,57-20	87004775
90029606	136-5152-42-24,57-20	87004775
90029605	136-5152-42-24-67,57-20	87004775
90029766	137-5152-42-24,57-20	87004775

United in performance. Inspired by innovation.

Performance unites us, innovation inspires us, and commitment drives us to keep moving forward. Count on Epiroc to deliver the solutions you need to succeed today and the technology to lead tomorrow.
[epiroc.com](https://www.epiroc.com)

